

PRODUCT SPECIFICATION

COSMO ELECTRONICS CORP.	Photocoupler : KP3020	SHEET 1 OF 5
-----------------------------------	---------------------------------	--------------

High Reliability Photocoupler

● Features

1. Current transfer ratio

(CTR : MIN. 60% at $I_F = \pm 1\text{mA}$ $V_{ce} = 5\text{V}$)

2. High isolation voltage between input and output (Viso : 5000Vrms).
3. Compact dual-in-line package.
4. AC input.

● Applications

1. Programmable Controller Applications for Low Input Photocouplers and High Vceo Photocouplers.
2. Telephone sets, telephone exchangers.
3. System appliances. •Limit Switches •Sensors •Thermostats •Transducers etc.
4. Signal transmission between circuits of different potentials and impedances.

PRODUCT SPECIFICATION

COSMO ELECTRONICS CORP.	Photocoupler : KP3020	SHEET 2 OF 5
-----------------------------------	---------------------------------	---------------------

1. OUTSIDE DIMENSION : UNIT (mm)

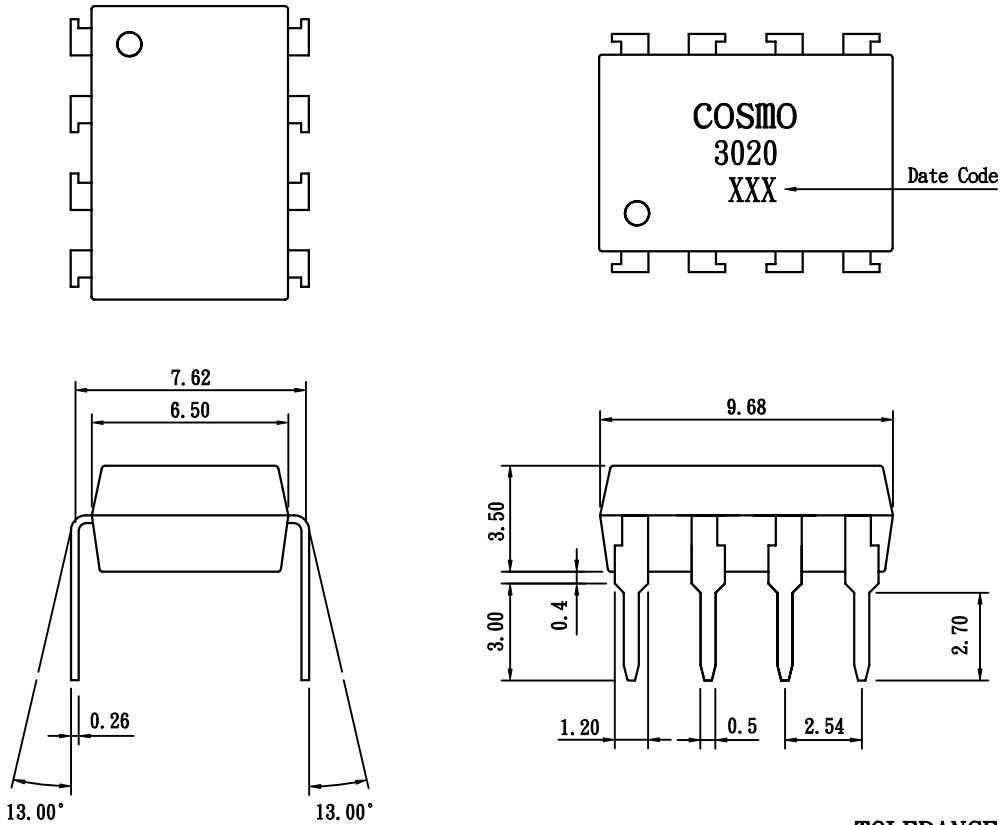

TOLERANCE : $\pm 0.2\text{mm}$

2. SCHEMATIC : TOP VIEW

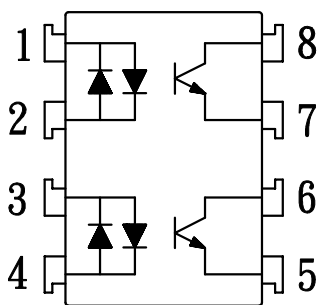

- 1, 2. Anode, Cathode
- 3, 4. Anode, Cathode
- 5, 7. Emitter
- 6, 8. Collector

PRODUCT SPECIFICATION

COSMO ELECTRONICS CORP.	Photocoupler : KP3020	SHEET 3 OF 5
-----------------------------------	---------------------------------	---------------------

• Absolute Maximum Ratings

(Ta=25°C)

Parameter		Symbol	Rating	Unit
Input	Forward current	IF	± 50	mA
	Peak forward current	IFM	± 1	A
	Power dissipation	PD	70	mW
Output	Collector-emitter voltage	VCE0	60	V
	Emitter-collector voltage	VECO	6	V
	Collector current	Ic	50	mA
	Collector power dissipation	Pc	150	mW
Total power dissipation		Ptot	200	mW
Isolation voltage 1 minute		Viso	5000	Vrms
Operating temperature		Topr	-30 to +100	° C
Storage temperature		Tstg	-55 to +125	° C
Soldering temperature 10 second		Tsol	260	° C

• Electro-optical Characteristics

(Ta=25°C)

Parameter		Symbol	Conditions	MIN.	TYP.	MAX.	Unit
Input	Forward voltage	VF	IF=± 20mA	-	1.2	1.4	V
	Peak forward voltage	VFM	IFM=± 0.5A	-	-	3.5	V
	Terminal capacitance	Ct	V=0, f=1kHz	-	30	-	pF
Output	Collector dark current	ICE0	VCE=20V, IF=0	-	-	0.1	uA
Transfer characteristics	Current transfer ratio	CTR	IF=± 1mA, VCE=5V	60	-	600	%
	Collector-emitter saturation voltage	VCE(sat)	IF=± 20mA, IC=1mA	-	0.1	0.3	V
	Isolation resistance	Riso	DC500V	5x10 ¹⁰	10 ¹¹	-	ohm
	Floating capacitance	Cf	V=0, f=1MHz	-	0.6	1.0	pF
	Cut-off frequency	fc	VCC=5V, IC=2mA, RL=100ohm	-	80	-	kHz
	Response time (Rise)	tr	VCC=2V, IC=2mA, RL=100ohm	-	5	20	us
	Response time (Fall)	tf		-	4	20	us

Fig.1 Current Transfer Ratio vs. Forward Current

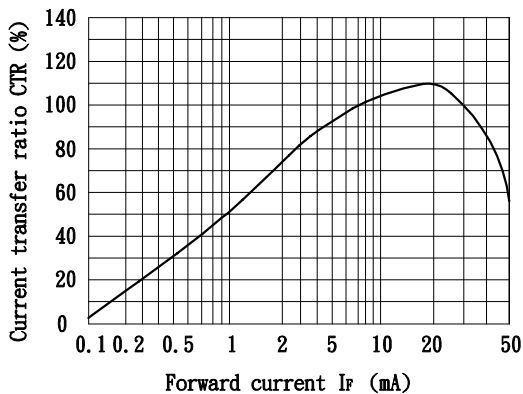

PRODUCT SPECIFICATION

COSMO
ELECTRONICS CORP.

Photocoupler :
KP3020

SHEET 4 OF 5

Fig. 2 Collector Power Dissipation vs. Ambient Temperature

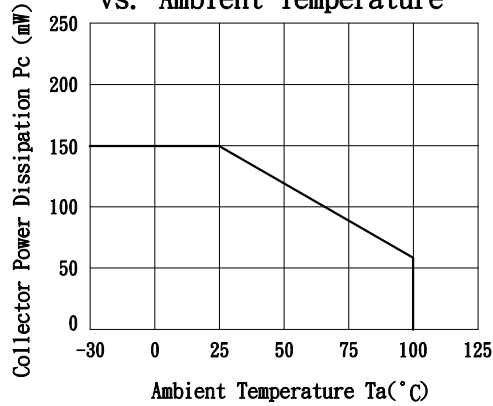

Fig. 3 Collector Dark Current vs. Ambient Temperature

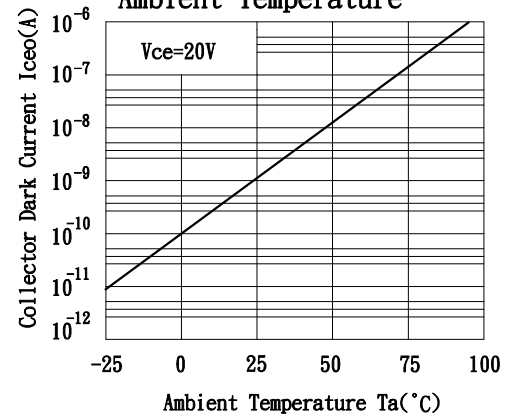

Fig. 4 Forward Current vs. Ambient Temperature

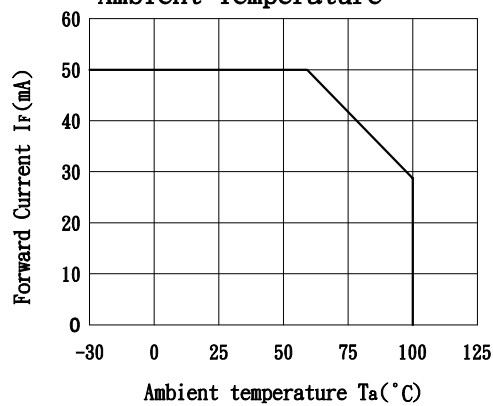

Fig. 5 Forward Current vs. Forward Voltage

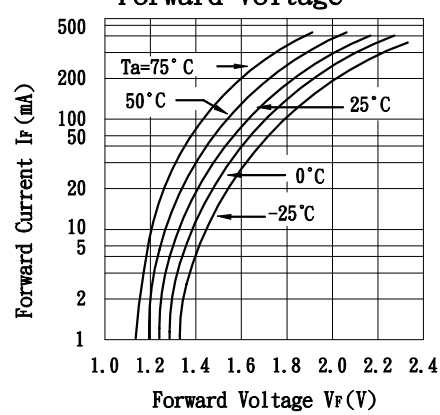

Fig. 6 Collector Current vs. Collector-emitter Voltage

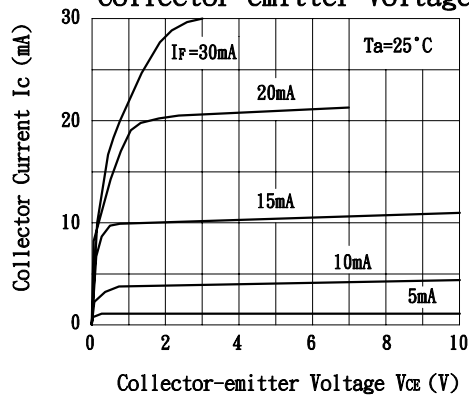
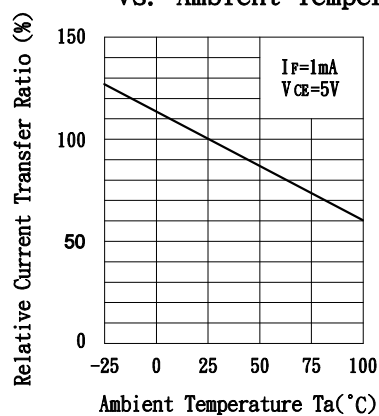

Fig. 7 Relative Current Transfer Ratio vs. Ambient Temperature



PRODUCT SPECIFICATION

<p>COSMO ELECTRONICS CORP.</p>	<p>Photocoupler : KP3020</p>	<p>SHEET 5 OF 5</p>
---	---	---------------------

Collector-emitter Saturation Voltage vs. Ambient Temperature

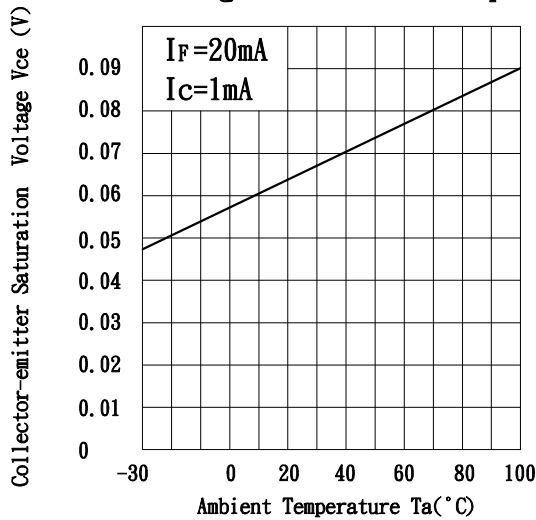

Fig. 9 Collector-emitter Saturation Voltage vs. Forward Current

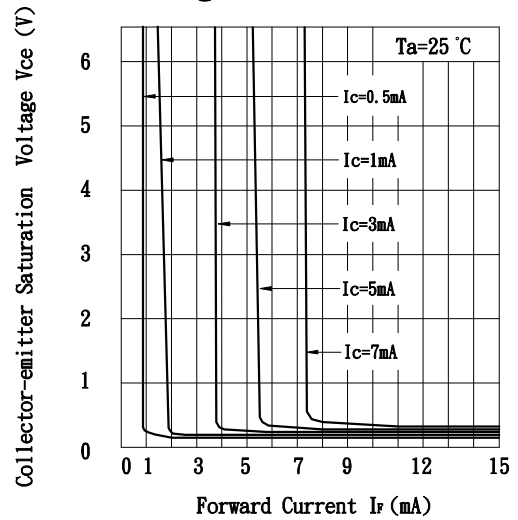

Fig. 10 Response Time vs. Load Resistance

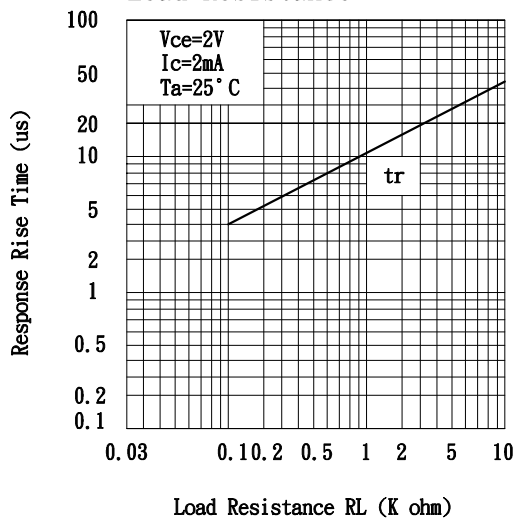

Fig. 11 Response Time vs. Load Resistance

