

FEATURES

Ultralow Offset Voltage:

$T_A = 25^\circ\text{C}$: 25 μV Max

Outstanding Offset Voltage Drift: 0.1 $\mu\text{V}/^\circ\text{C}$ Max

Excellent Open-Loop Gain and Gain Linearity:

12 $\text{V}/\mu\text{V}$ Typ

CMRR: 130 dB Min

PSRR: 115 dB Min

Low Supply Current: 2.0 mA Max

**Fits Industry Standard Precision Op Amp Sockets
(OP07/OP77)**

PIN CONNECTIONS

Epoxy Mini-DIP

(P Suffix)

8-Pin SO

(S-Suffix)

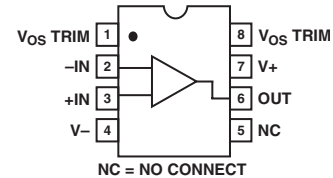

GENERAL DESCRIPTION

The OP177 features the highest precision performance of any op amp currently available. Offset voltage of the OP177 is only 25 μV max at room temperature. The ultralow V_{OS} of the OP177 combines with its exceptional offset voltage drift (TCV_{OS}) of 0.1 $\mu\text{V}/^\circ\text{C}$ max to eliminate the need for external V_{OS} adjustment and increases system accuracy over temperature.

The OP177's open-loop gain of 12 $\text{V}/\mu\text{V}$ is maintained over the full $\pm 10 \text{ V}$ output range. CMRR of 130 dB min, PSRR of 120 dB min, and maximum supply current of 2 mA are just a few examples of the excellent performance of this operational amplifier. The OP177's combination of outstanding specifications ensures accurate performance in high closed-loop gain applications.

This low noise bipolar input op amp is also a cost effective alternative to chopper-stabilized amplifiers. The OP177 provides chopper-type performance without the usual problems of high noise, low frequency chopper spikes, large physical size, limited common-mode input voltage range, and bulky external storage capacitors.

The OP177 is offered in the -40°C to $+85^\circ\text{C}$ extended industrial temperature ranges. This product is available in 8-pin epoxy DIPs, as well as the space saving 8-pin Small-Outline (SO).

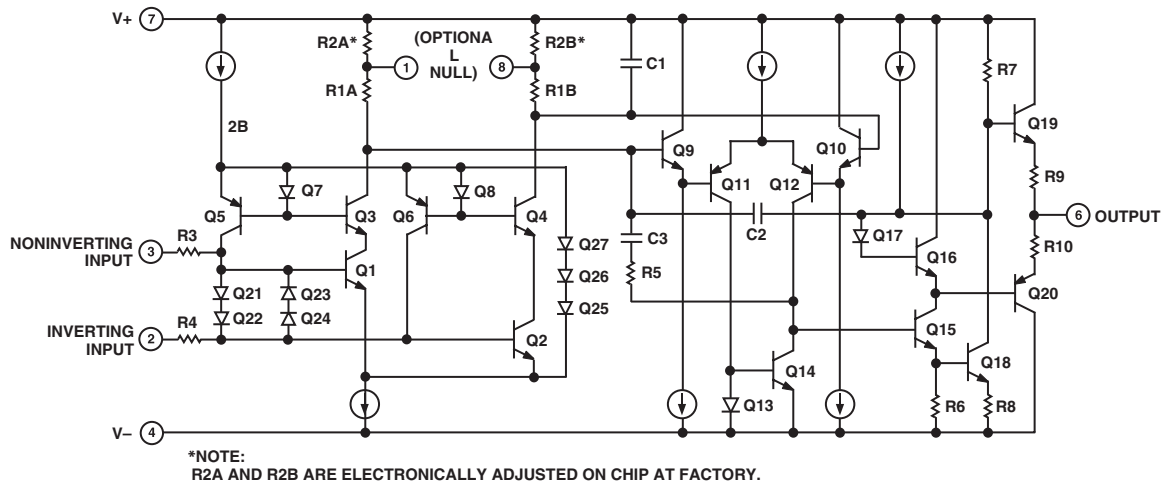

Figure 1. Simplified Schematic

REV. C

Information furnished by Analog Devices is believed to be accurate and reliable. However, no responsibility is assumed by Analog Devices for its use, nor for any infringements of patents or other rights of third parties that may result from its use. No license is granted by implication or otherwise under any patent or patent rights of Analog Devices.

ELECTRICAL CHARACTERISTICS (@ $V_S = \pm 15\text{ V}$, $T_A = 25^\circ\text{C}$, unless otherwise noted.)

Parameter	Symbol	Conditions	OP177F			OP177G			Unit
			Min	Typ	Max	Min	Typ	Max	
INPUT OFFSET VOLTAGE	V_{OS}		10	25		20	60	μV	
LONG-TERM INPUT OFFSET Voltage Stability	$\Delta V_{OS}/\text{Time}$		0.3			0.4		$\mu\text{V}/\text{Mo}$	
INPUT OFFSET ¹ CURRENT	I_{OS}		0.3	1.5		0.3	2.8	nA	
INPUT BIAS CURRENT	I_B		-0.2	1.2	2	-0.2	1.2	2.8	nA
INPUT NOISE VOLTAGE	e_n	$f_o = 1\text{ Hz to }100\text{ Hz}^2$	118	150		118	150	nV rms	
INPUT NOISE CURRENT	i_n	$f_o = 1\text{ Hz to }100\text{ Hz}^2$	3	8		3	8	pA rms	
INPUT RESISTANCE Differential-Mode ³	R_{IN}		26	45		18.5	45	$\text{M}\Omega$	
INPUT RESISTANCE COMMON-MODE	R_{INCM}		200			200		$\text{G}\Omega$	
INPUT VOLTAGE RANGE ⁴	IVR		± 13	± 14		± 13	± 14	V	
COMMON-MODE REJECTION RATIO	CMRR	$V_{CM} = \pm 13\text{ V}$	130	140		115	140	dB	
POWER SUPPLY REJECTION RATIO	PSRR	$V_S = \pm 3\text{ V to } \pm 18\text{ V}$	115	125		110	120	dB	
LARGE SIGNAL VOLTAGE GAIN	A_{VO}	$R_L \geq 2\text{ k}\Omega$, $V_O = 610\text{ V}^5$	5000	12000		2000	6000	V/mV	
OUTPUT VOLTAGE SWING	V_O	$R_L \geq 10\text{ k}\Omega$ $R_L \geq 2\text{ k}\Omega$ $R_L \geq 1\text{ k}\Omega$	± 13.5 ± 12.5 ± 12.0	± 14.0 ± 13.0 ± 12.5		± 13.5 ± 12.5 ± 12.0	± 14.0 ± 13.0 ± 12.5	V V V	
SLEW RATE ²	SR	$R_L \geq 2\text{ k}\Omega$	0.1	0.3		0.1	0.3	V/ μs	
CLOSED-LOOP BANDWIDTH ²	BW	$A_{VCL} = 1$	0.4	0.6		0.4	0.6	MHz	
OPEN-LOOP OUTPUT RESISTANCE	R_O		60			60		Ω	

POWER CONSUMPTION	P_D	$V_S = \pm 15\text{ V},$ No Load	50	60	50	60	mW
			$V_S = \pm 3\text{ V},$ No Load	3.5	4.5	3.5	4.5
SUPPLY CURRENT	I_{SY}	$V_S = \pm 15\text{ V},$ No Load	1.6	2	1.6	2	mA
OFFSET ADJUSTMENT RANGE		$R_P = 20\text{ k}\Omega$	± 3		± 3		mV

NOTES

¹Long-Term Input Offset Voltage Stability refers to the averaged trend line of V_{OS} versus time over extended periods after the first 30 days of operation. Excluding the initial hour of operation, changes in V_{OS} during the first 30 operating days are typically less than 2.0 μV .

²Sample tested.

³Guaranteed by design.

⁴Guaranteed by CMRR test condition.

⁵To ensure high open-loop gain throughout the $\pm 10\text{ V}$ output range, A_{VO} is tested at $-10\text{ V} \leq V_O \leq 0\text{ V}$, $0\text{ V} \leq V_O \leq +10\text{ V}$, and $-10\text{ V} \leq V_O \leq +10\text{ V}$.

Specifications subject to change without notice.

OP177—SPECIFICATIONS

ELECTRICAL CHARACTERISTICS (@ $V_S = \pm 15\text{ V}$, $-40^\circ\text{C} \leq T_A \leq 85^\circ\text{C}$, unless otherwise noted.)

Parameter	Symbol	Conditions	OP177F			OP177G			Unit
			Min	Typ	Max	Min	Typ	Max	
INPUT OFFSET VOLTAGE	V_{OS}			15	40		20	100	μV
AVERAGE INPUT OFFSET VOLTAGE DRIFT ¹	TCV_{OS}			0.1	0.3		0.7	1.2	$\mu\text{V}/^\circ\text{C}$
INPUT OFFSET CURRENT	I_{OS}			0.5	2.2		0.5	4.5	nA
AVERAGE INPUT OFFSET CURRENT DRIFT ²	TCI_{OS}			1.5	40		1.5	85	$\text{pA}/^\circ\text{C}$
INPUT BIAS CURRENT	I_B		-0.2	2.4	4		2.4	± 6	nA
AVERAGE INPUT BIAS CURRENT DRIFT ²	TCI_B			8	40		15	60	$\text{pA}/^\circ\text{C}$
INPUT VOLTAGE RANGE ³	IVR		± 13	± 13.5		± 13	± 13.5		V
COMMON-MODE REJECTION RATIO	CMRR	$V_{CM} = \pm 13\text{ V}$	120	140		110	140		dB
POWER SUPPLY REJECTION RATIO	PSSR	$V_S = \pm 3\text{ V to } \pm 18\text{ V}$	110	120		106	115		dB
LARGE-SIGNAL VOLTAGE GAIN ⁴	A_{VO}	$R_L \geq 2\text{ k}\Omega$, $V_O = 10\text{ V}$	2000	6000		1000	4000		V/mV
OUTPUT VOLTAGE SWING	V_O	$R_L \geq 2/\text{k}\Omega$	± 12	± 13		± 12	± 13		V
POWER CONSUMPTION	P_D	$V_S = \pm 15\text{ V}$, No Load		60	75		60	75	mW
SUPPLY CURRENT	I_{SY}	$V_S = \pm 15\text{ V}$, No Load		20	2.5		2	2.5	mA

NOTES

¹OP177TCV_{OS} is sample tested.

²Guaranteed by endpoint limits.

³Guaranteed by CMRR test condition.

⁴To ensure high open-loop gain throughout the $\pm 10\text{ V}$ output range, A_{VO} is tested at $-10\text{ V} \leq V_O \leq 0\text{ V}$, $0\text{ V} \leq V_O \leq +10\text{ V}$, and $-10\text{ V} \leq V_O \leq +10\text{ V}$.

Specifications subject to change without notice.

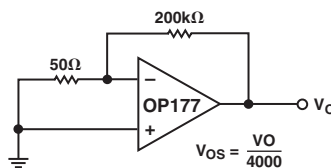

Figure 2. Typical Offset Voltage Test Circuit

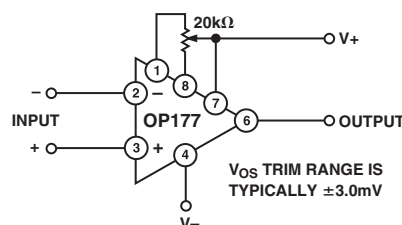

Figure 3. Optional Offset Nulling Circuit

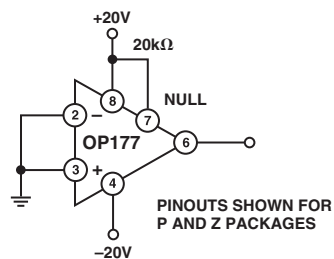

Figure 4. Burn-In Circuit

ABSOLUTE MAXIMUM RATINGS

Supply Voltage	±22 V
Internal Power Dissipation ¹	500 mW
Differential Input Voltage	±30 V
Input Voltage	±22 V
Output Short-Circuit Duration	Indefinite
Storage Temperature Range	
S, P Package	-65°C to +125°C
Operating Temperature Range	
OP177F, OP177G	-40°C to +85°C
Lead Temperature Range (Soldering, 60 sec)	300°C
DICE Junction Temperature (T _J)	-65°C to +150°C

Package Type	θ_{JA}^2	θ_{JC}	Unit
8-Pin Plastic DIP (P)	103	43	°C/W
8-Pin SO (S)	158	43	°C/W

NOTES

¹For supply voltages less than ±22 V, the absolute maximum input voltage is equal to the supply voltage.

² θ_{JA} is specified for worst-case mounting conditions, i.e., θ_{JA} is specified for device in socket for P-DIP; θ_{JA} is specified for device soldered to printed circuit board for SO package.

ORDERING GUIDE

Model	Temperature Range	Package Description	Package Option
OP177FP	-40°C to +85°C	8-Pin Plastic DIP	N-8
OP177GP	-40°C to +85°C	8-Pin Plastic DIP	N-8
OP177FS	-40°C to +85°C	8-Pin SO	SO-8
OP177GS	-40°C to +85°C	8-Pin SO	SO-8

OP177—Typical Performance Characteristics

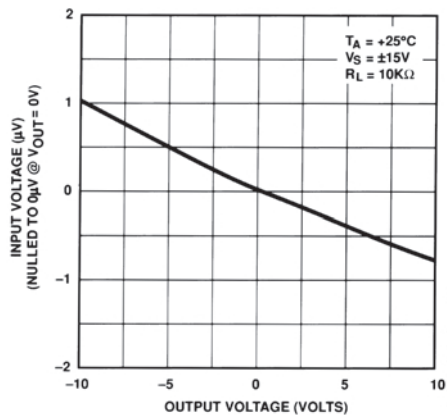

TPC 1. Gain Linearity (Input Voltage vs. Output Voltage)

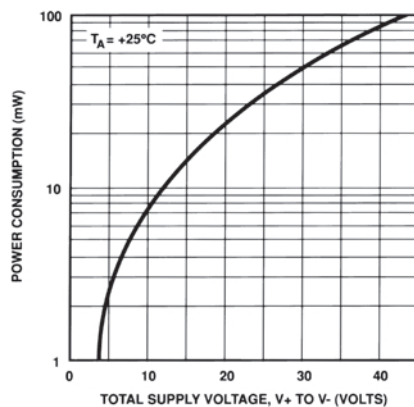

TPC 2. Power Consumption vs. Power Supply

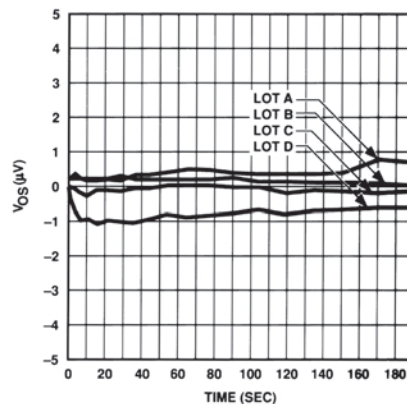

TPC 3. Warm-Up V_{OS} Drift (Normalized) Z Package

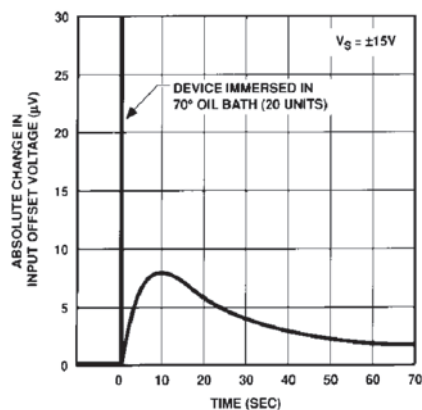

TPC 4. Offset Voltage Change Due to Thermal Shock

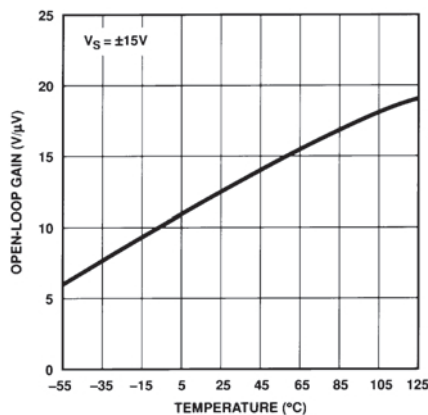

TPC 5. Open-Loop Gain vs. Temperature

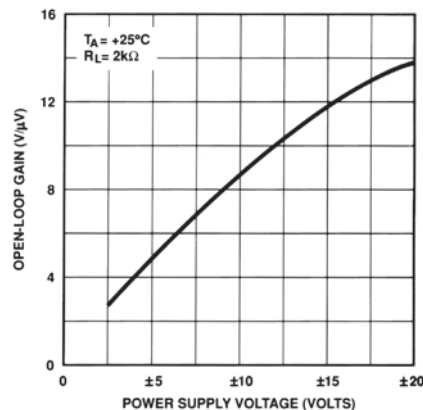

TPC 6. Open-Loop Gain vs. Power Supply Voltage

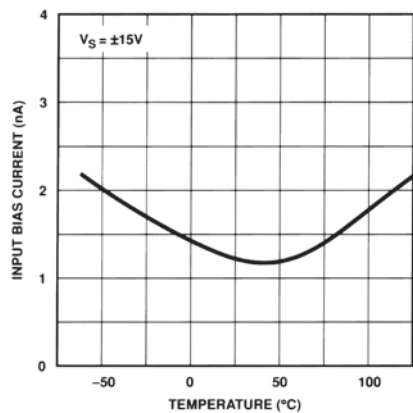

TPC 7. Input Bias Current vs. Temperature

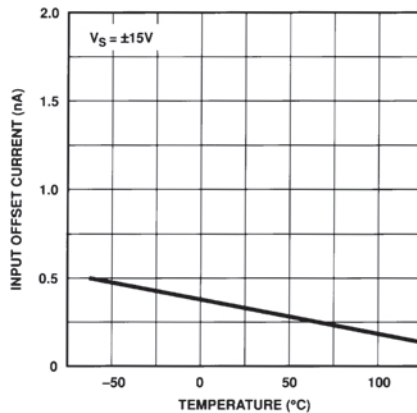

TPC 8. Input Offset Current vs. Temperature

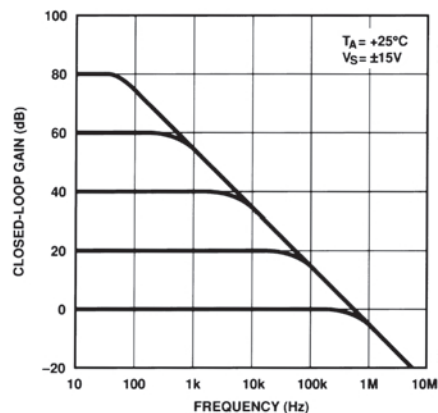

TPC 9. Closed-Loop Response for Various Gain Configurations

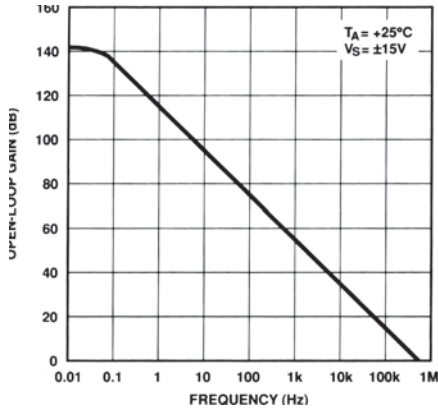

TPC 10. Open-Loop Frequency Response

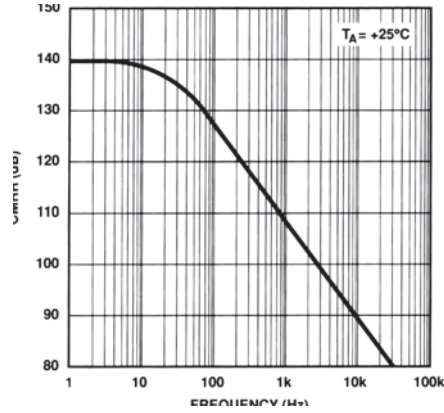

TPC 11. CMRR vs. Frequency

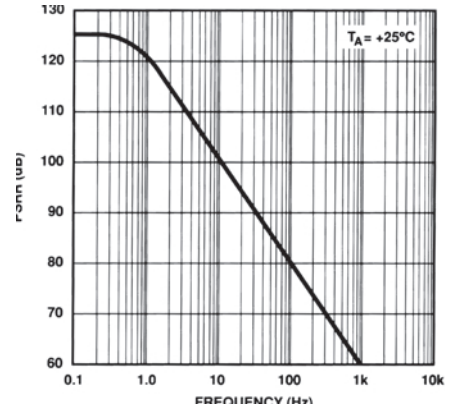

TPC 12. PSRR vs. Frequency

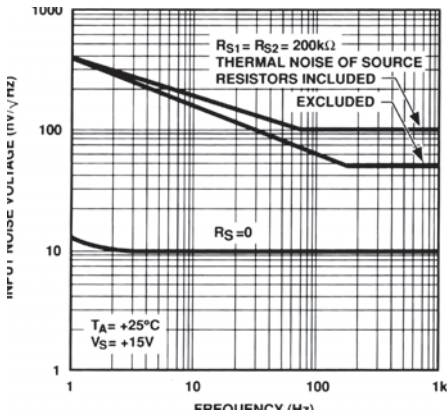

TPC 13. Total Input Noise Voltage vs. Frequency

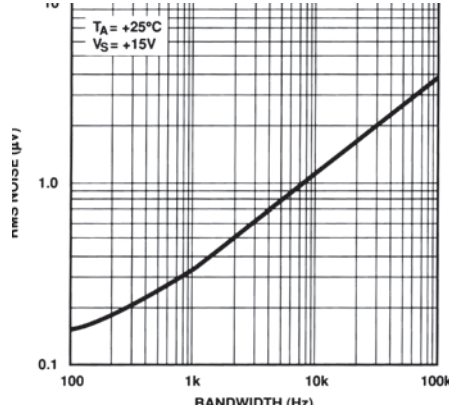

TPC 14. Input Wideband Noise vs. Bandwidth (0.1 Hz to Frequency Indicated)

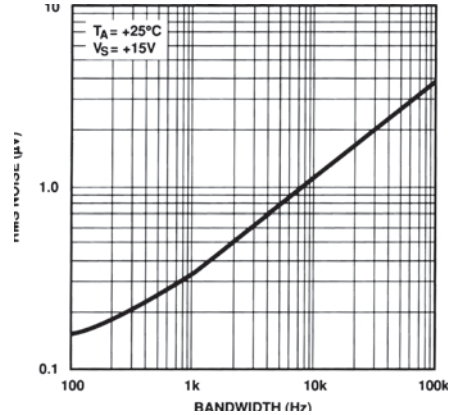

TPC 15. Maximum Output Swing vs. Frequency

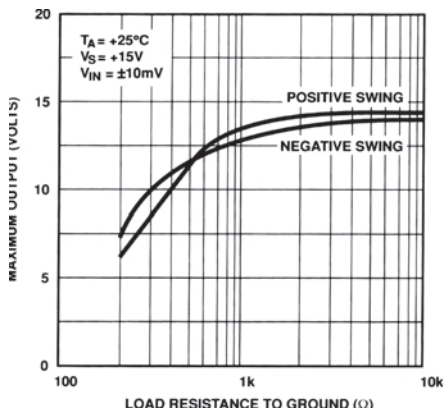

TPC 16. Maximum Output Voltage vs. Load Resistance

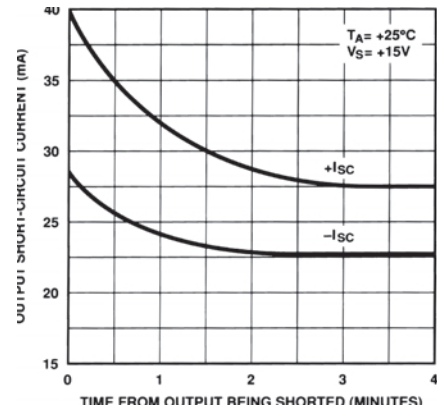

TPC 17. Output Short-Circuit Current vs. Time

OP177

APPLICATION INFORMATION

Gain Linearity

The actual open-loop gain of most monolithic op amps varies at different output voltages. This nonlinearity causes errors in high closed-loop gain circuits.

It is important to know that the manufacturer's A_{VO} specification is only a part of the solution, since all automated testers use endpoint testing and, therefore, show only the average gain. For example, Figure 5 shows a typical precision op amp with a respectable open-loop gain of 650 V/mV. However, the gain is not constant through the output voltage range, causing nonlinear errors. An ideal op amp would show a horizontal scope trace.

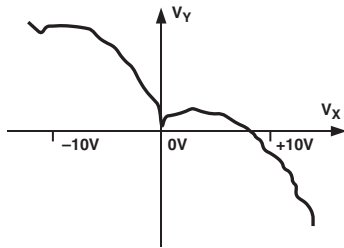

Figure 5. Typical Precision Op Amp

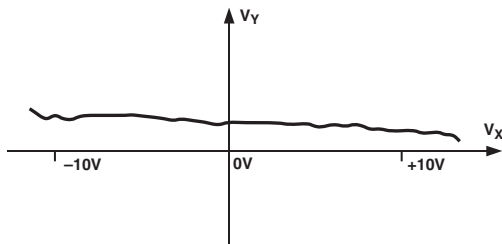

Figure 6. Output Gain Linearity Trace

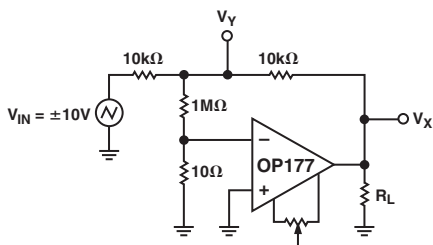

Figure 7. Open-Loop Gain Linearity Test Circuit

Figure 6 shows the OP177's output gain linearity trace with its truly impressive average A_{VO} of 12000 V/mV. The output trace is virtually horizontal at all points, assuring extremely high gain accuracy. ADI also performs additional testing to ensure consistent high open-loop gain at various output voltages.

Figure 7 is a simple open-loop gain test circuit for your own evaluation.

THERMOCOUPLE AMPLIFIER WITH COLD-JUNCTION COMPENSATION

An example of a precision circuit is a thermocouple amplifier that must amplify very low level signals accurately without introducing linearity and offset errors to the circuit. In this circuit, an S-type thermocouple, which has a Seebeck coefficient of $10.3 \mu\text{V}/^\circ\text{C}$, produces 10.3 mV of output voltage at a temperature of 1000°C . The amplifier gain is set at 973.16. Thus, it will produce an output voltage of 10.024 V. Extended temperature ranges to beyond 1500°C can be accomplished by reducing the amplifier gain. The circuit uses a low-cost diode to sense the temperature at the terminating junctions and, in turn, compensates for any ambient temperature change. The OP177, with its high open-loop gain, plus low offset voltage and drift combines to yield a very precision temperature sensing circuit. Circuit values for other thermocouple types are shown in Table I.

Table I.

Thermocouple Type	Seebeck Coefficient	R1	R2	R7	R9
K	$39.2 \mu\text{V}/^\circ\text{C}$	110 Ω	5.76 k Ω	102 k Ω	269 k Ω
J	$50.2 \mu\text{V}/^\circ\text{C}$	100 Ω	4.02 k Ω	80.6 k Ω	200 k Ω
S	$10.3 \mu\text{V}/^\circ\text{C}$	100 Ω	20.5 k Ω	392 k Ω	1.07 M Ω

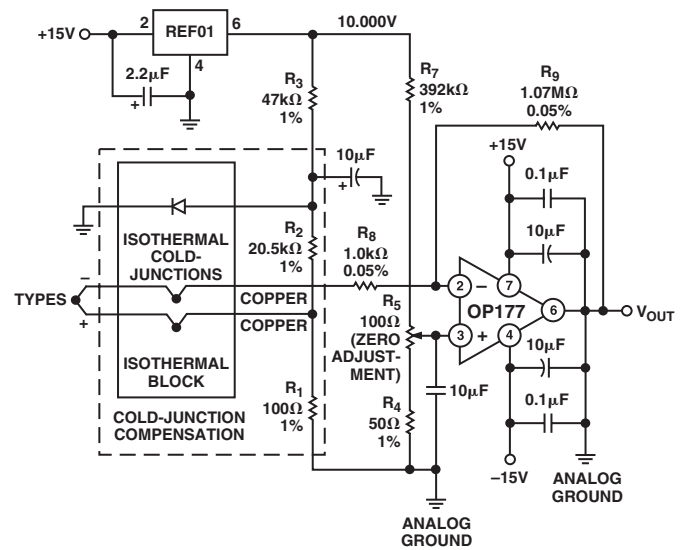

Figure 8. Thermocouple Amplifier with Cold Junction Compensation

PRECISION HIGH GAIN DIFFERENTIAL AMPLIFIER

The high gain, gain linearity, CMRR, and low TCV_{OS} of the OP177 make it possible to obtain performance not previously available in single stage, very high gain amplifier applications. See Figure 9.

For best CMR, $\frac{R1}{R2}$ must equal $\frac{R3}{R4}$. In this example, with a 10 mV differential signal, the maximum errors are as listed in Table II.

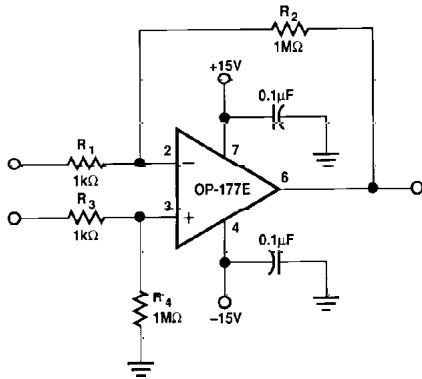

Figure 9. Precision High Gain Differential Amplifier

Table II. High Gain Differential Amp Performance

Type	Amount
Common-Mode Voltage	0.1%/V
Gain Linearity, Worst Case	0.02%
TCV _{OS}	0.0003%/°C
TCI _{OS}	0.008%/°C

ISOLATING LARGE CAPACITIVE LOADS

The circuit in Figure 10 reduces maximum slew rate but allows driving capacitive loads of any size without instability. Because the 100 Ω resistor is inside the feedback loop, its effect on output impedance is reduced to insignificance by the high open-loop gain of the OP177.

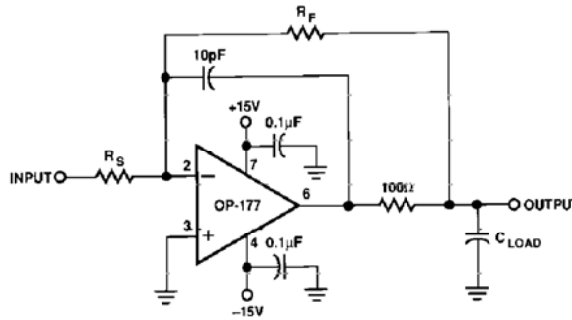
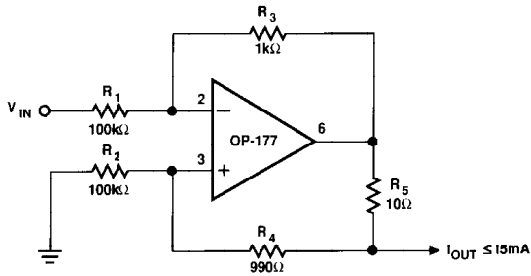
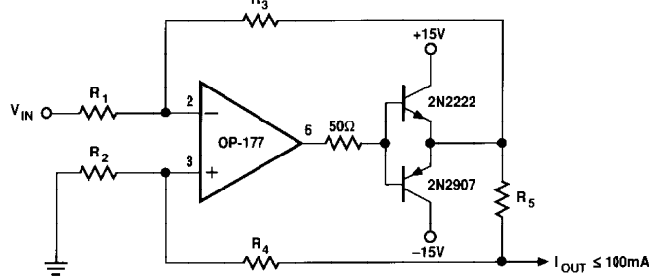

Figure 10. Isolating Capacitive Loads

BASIC CURRENT SOURCE



100mA CURRENT SOURCE



$$I_{OUT} = V_{IN} \frac{R_3}{R_1 \cdot R_5}$$

GIVEN $R_3 = R_4 + R_5$, $R_1 = R_2$

Figure 11. Bilateral Current Source

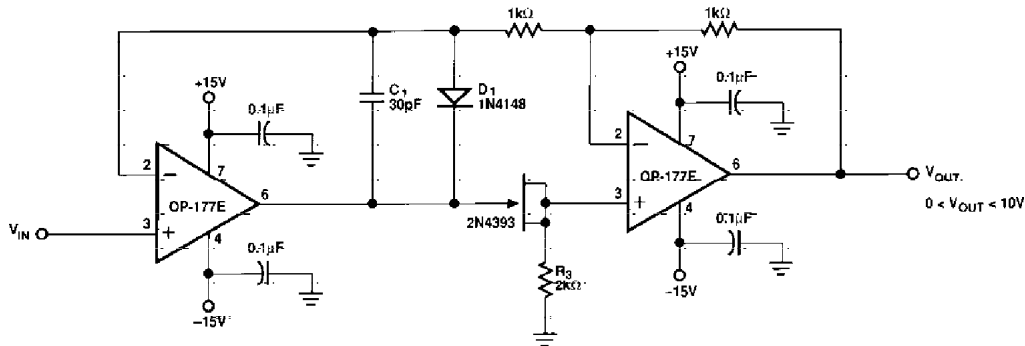

Figure 12. Precision Absolute Value Amplifier

OP177

BILATERAL CURRENT SOURCE

The current sources shown in Figure 11 will supply both positive and negative current into a grounded load.

$$\text{Note that } Z_O = \frac{R5 \left(\frac{R4}{R2} + 1 \right)}{\frac{R5 + R4}{R2} - \frac{R3}{R1}}$$

and that for Z_O to be infinite,

$$\frac{R5 + R4}{R2} \text{ must} = \frac{R3}{R1}$$

PRECISION ABSOLUTE VALUE AMPLIFIER

The high gain and low TCV_{OS} assure accurate operation with inputs from microvolts to volts. In this circuit, the signal always appears as a common-mode signal to the op amps. See Figure 12.

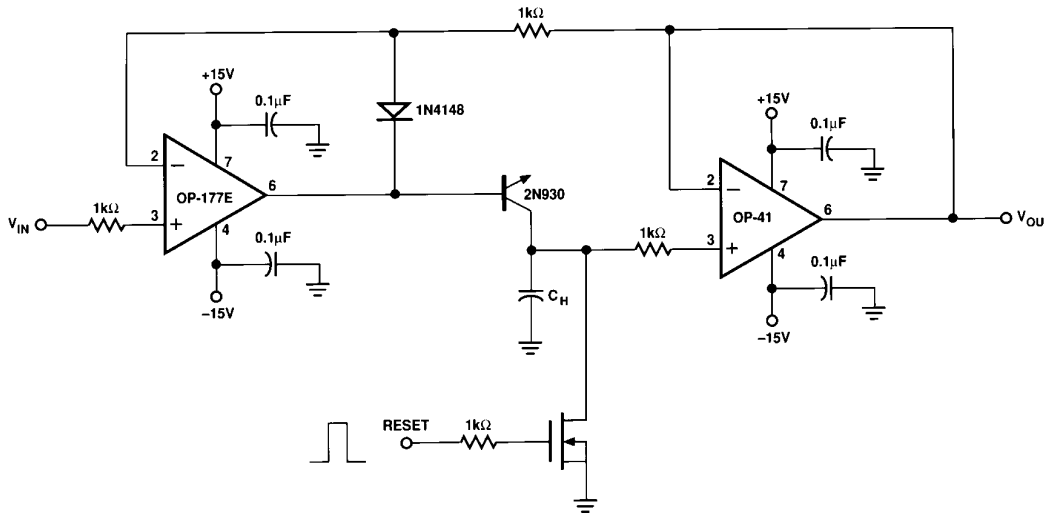

Figure 13. Precision Positive Peak Detector

PRECISION POSITIVE PEAK DETECTOR

In Figure 13, the C_H must be of polystyrene, Teflon,* or polyethylene to minimize dielectric absorption and leakage. The droop rate is determined by the size of C_H and the bias current of the OP41.

PRECISION THRESHOLD DETECTOR/AMPLIFIER

In Figure 14, when $V_{IN} < V_{TH}$, amplifier output swings negative, reverse biasing diode D_1 . $V_{OUT} = V_{TH}$ if $R_L = \infty$. When $V_{IN} \geq V_{TH}$, the loop closes,

$$V_{OUT} = V_{TH} + (V_{IN} - V_{TH}) \left(1 + \frac{R_F}{R_S} \right)$$

C_C is selected to smooth the response of the loop.

*Teflon is a registered trademark of DuPont.

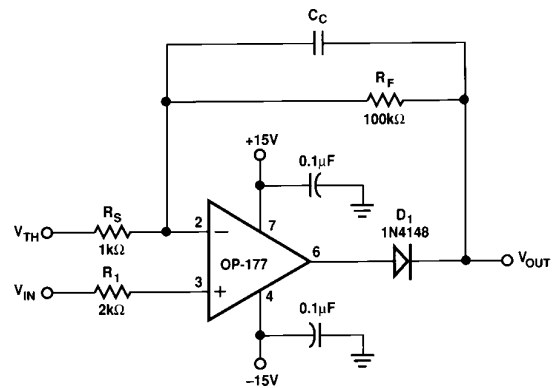
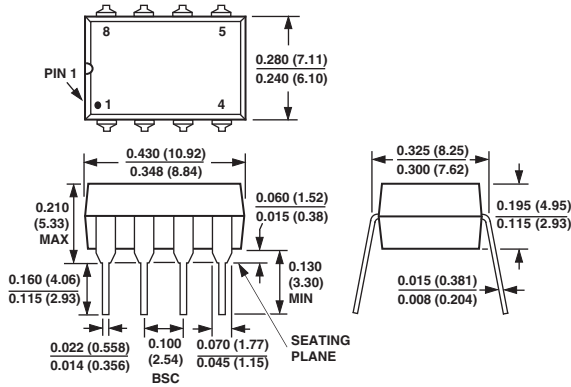

Figure 14. Precision Threshold Detector/Amplifier

OUTLINE DIMENSIONS

Dimensions shown in inches and (mm).

**8-Pin Plastic DIP
(N-8)**



**8-Pin SO
(SO-08)**

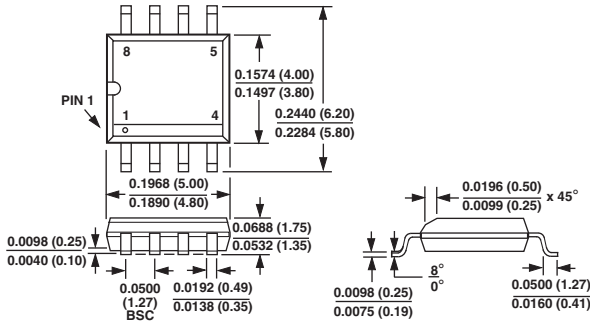

Revision History

Location	Page
01/30—Data Sheet changed from REV. B to REV. C.	
Edits to FEATURES	1
Edits to GENERAL DESCRIPTION	1
Edits to PIN CONNECTIONS	1
Edits to ELECTRICAL CHARACTERISTICS	2, 3
Global deletion of references to OP177E	3, 4, 10
Edits to ABSOLUTE MAXIMUM RATINGS	5
Edits to PACKAGE TYPE	5
Edits to ORDERING GUIDE	5
Edit to OUTLINE DIMENSIONS	11

